

PARTS LIST

FOR BLING RING 40T 01/02 PACKAGE
COMPATIBLE WITH **BAFANG BBS01/BBS02**

INCLUDES

- A** 1X LEKKIE BLING RING 40T 01/02
- B** 1X 2MM BLING RING 01/02 SPACER
- C** 1X DRIVE COVER 01/02 ASSEMBLY
- D** 1X DRIVE COVER 01/02 SPACER

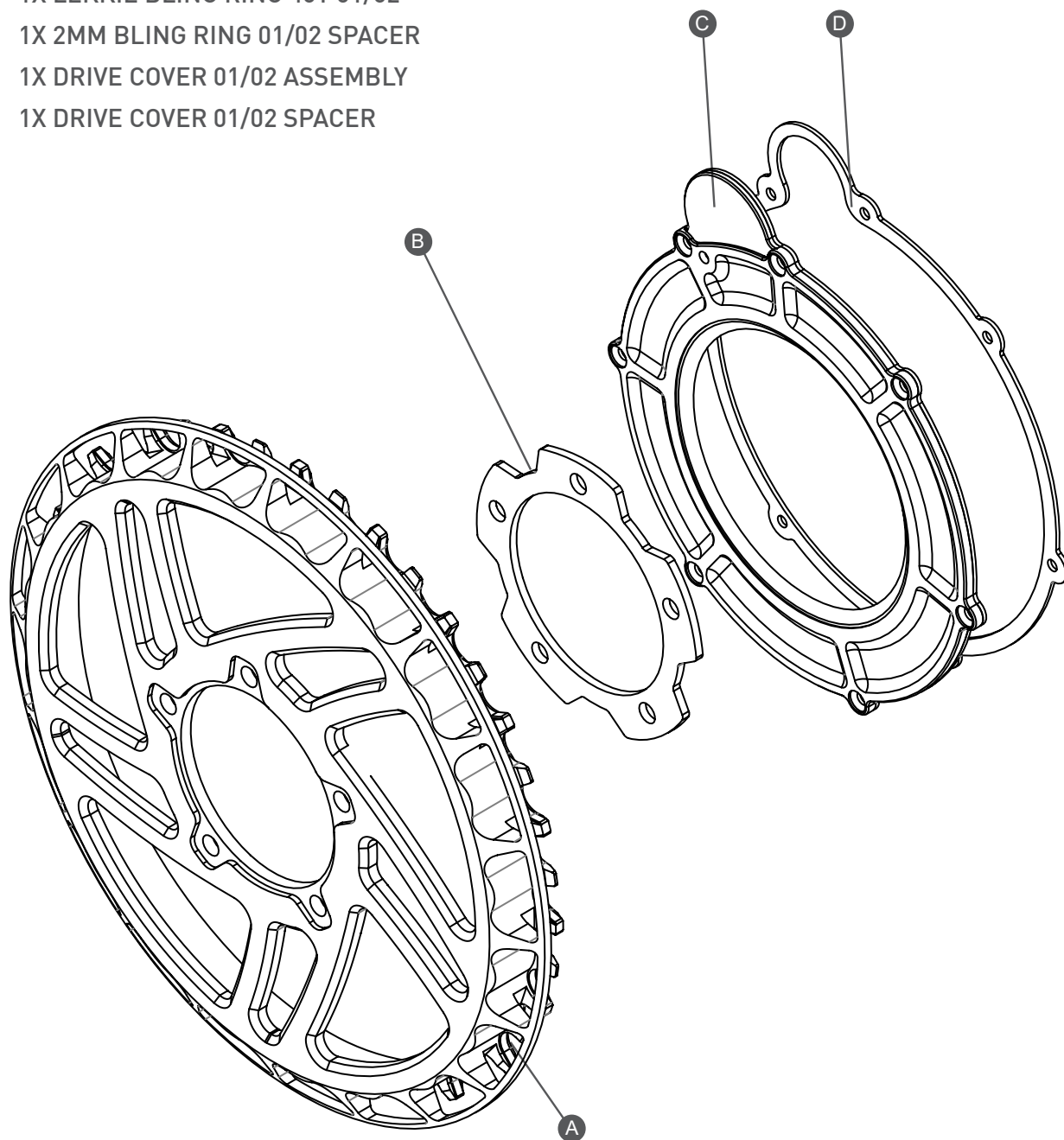

TIPS AND TRICKS

FOR LEKKIE DRIVE COVER 01/02.

COMPATIBLE WITH **BAFANG BBS01/BBS02 MOTOR**

INCLUDES

The Lekkie Drive Cover 01/02 has a gasket already assembled on the cover. These are the parts.

- A** 1X ALUMINIUM DRIVE COVER
- B** 1X RUBBER GASKET (PRE-GLUED)
- C** 1X GASKET SPACER

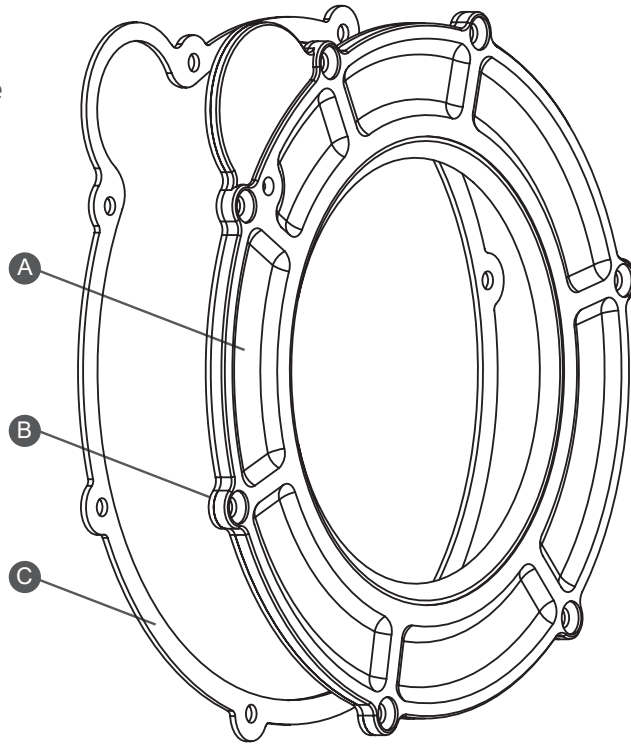

TOOLS REQUIRED

- Phillips driver
- Moly-grease
- All purpose lithium grease
- Loctite 243

When installing the Lekkie Drive Cover 01/02 you will require some tools and some hands on experience with your motor. If you do not have the required tools, confidence or skills to install this take your motor to your local bike shop or engineering shop and they should be able to help you out.

INSTALL TIPS

Here are some tips to keep in mind while completing the install.

- To keep everything running smooth and easy to maintain make sure you grease all metal to metal surfaces.
- Clean any excess grease out of the motor while it is open.
- Clean and grease the main gear and pinion.
- Always grease the axle taper before install cranks.

INSTALL

1. Unscrew the screws holding on the stock cover and remove.
2. Clean and lubricate the main drive gear.
3. Clean the mounting surface of the motor body.
4. Wipe a smudge of grease onto the inside edge of the rubber lip of the Lekkie Drive Cover.
5. *Place the spacer gasket on the back surface of the drive cover. Note, the gasket is assymetrical, please ensure all screw holes are aligned.
6. Place some of the screws through the drive cove/spacer to hold the spacer in position during assembly.
7. Slide the Lekkie Drive Cover onto the motor.
8. Apply a drop of Loctite 243 to each screw and screw them in. Tighten screws until the Gasket is clamped + 1/2 a turn. (Do not overtighten as gasket may distort).

*Some motors have been found to drag on the underside of the rubber gasket causing excess friction. If this is the case, please use the gasket spacer to increase internal clearance.

GREASE PORT

To keep your motor running its best its important to regularly grease the main drive gear and pinion. We have added a grease port to the Lekkie Drive Cover 01/02 to allow this. To do so simply use a grease gun with needle point to squirt moly-grease in while slowly turning the motor. The port is positioned at the junction of the drive gear and pinion.

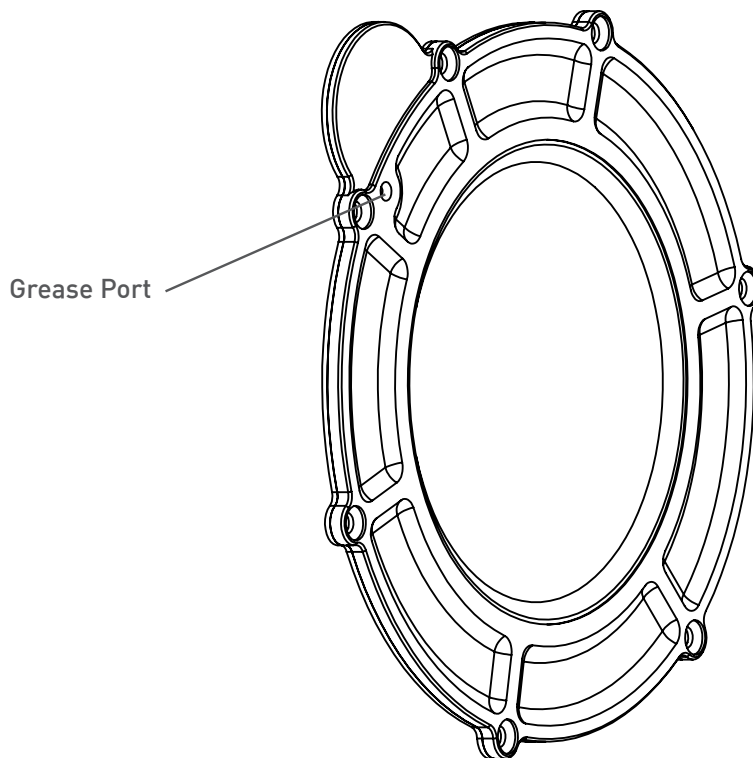

TIPS AND TRICKS

NEXT YOU CAN INSTALL THE **BLING RING 40T 01/02**

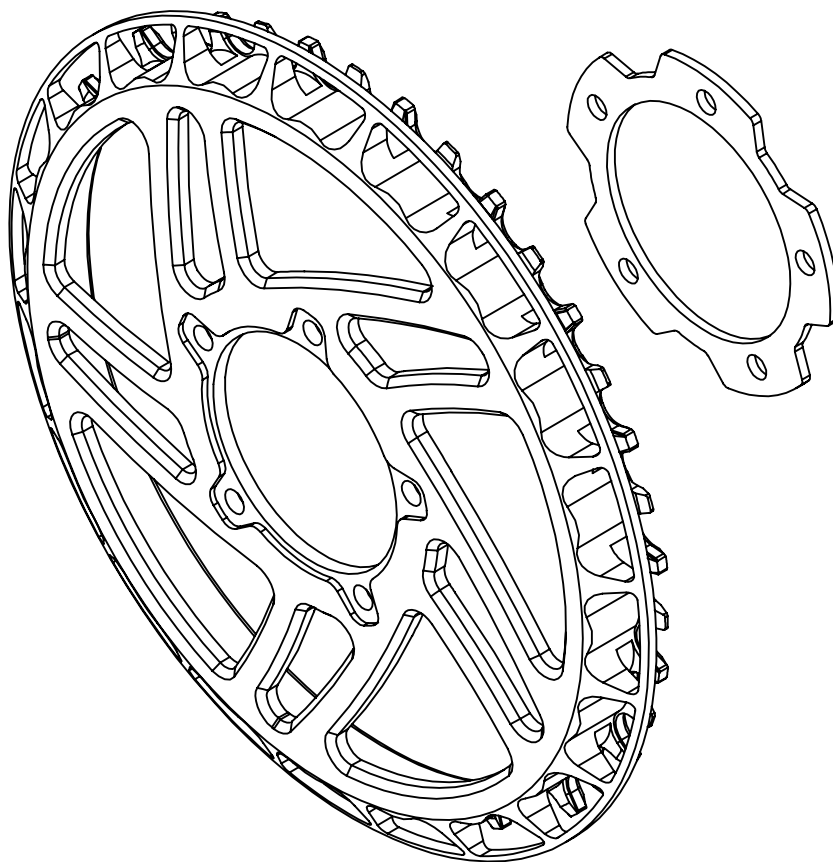

TOOLS REQUIRED

- 4mm hex key

INSTALL TIPS

- Clean and lubricate axle with a multi-purpose grease before install.
- Apply Loctite 243 to bolt thread.
- Always install a new chain when installing a Bling Ring
- If you are offsetting by more than 2mm use longer bolts.
- Make sure when you install your Bling Ring you have at least 1.5mm gap between wide tooth and chainstay to allow flex.
- Tighten to 6Nm
- Try to get the chainline to the centre of your cassette - see below for details.
- Clean and lubricate chain regularly.
- DO NOT use half links in the chain.
- Always grease axle before re-installing cranks.

DIMENSIONS

Here are the basic dimensions of the Bling Ring. Note the image is just an illustration to explain the drawing.

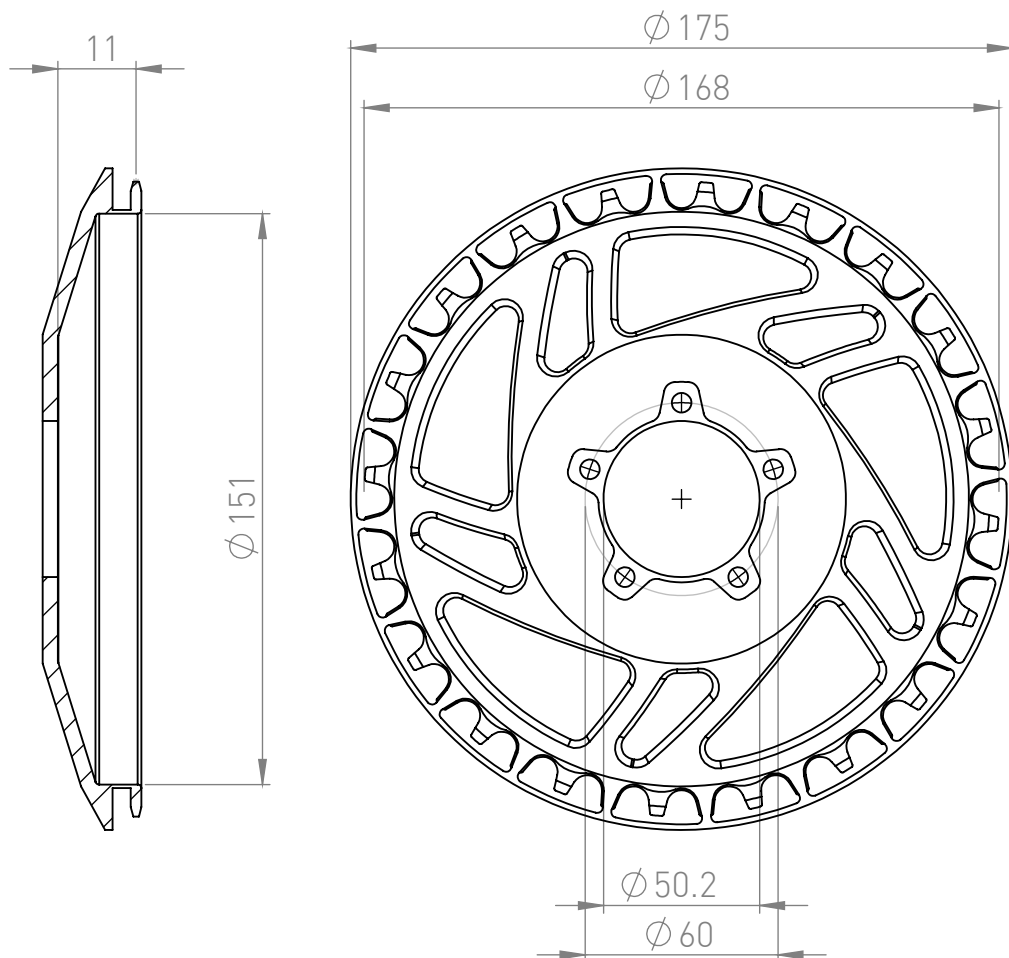

Note the package includes a 2mm Spacer so that you can space the Bling Ring out to the same offset as the original Bling Ring offset. We decided to offset the Bling Ring an extra 2mm so that users could try get that perfect chainline for the 73mm BB frames. If you are building a 73mm BB frame try installing without the spacer. You should have at least 1.5mm gap between the ring and chain-stay.

CHAINLINE

When building your machine you want to replicate the chainline that was on the bike before you converted it. Ideally you want the chainline to line up with the centre of your cassette.

The Blingring is designed to give you the best possible chainline however sometimes you may need to adjust your offset using spacers to get that chainline perfectly suited to the unique geometry of your build.

Some frames will not allow for a central chain line. In this case do the best you can to get the chain central.

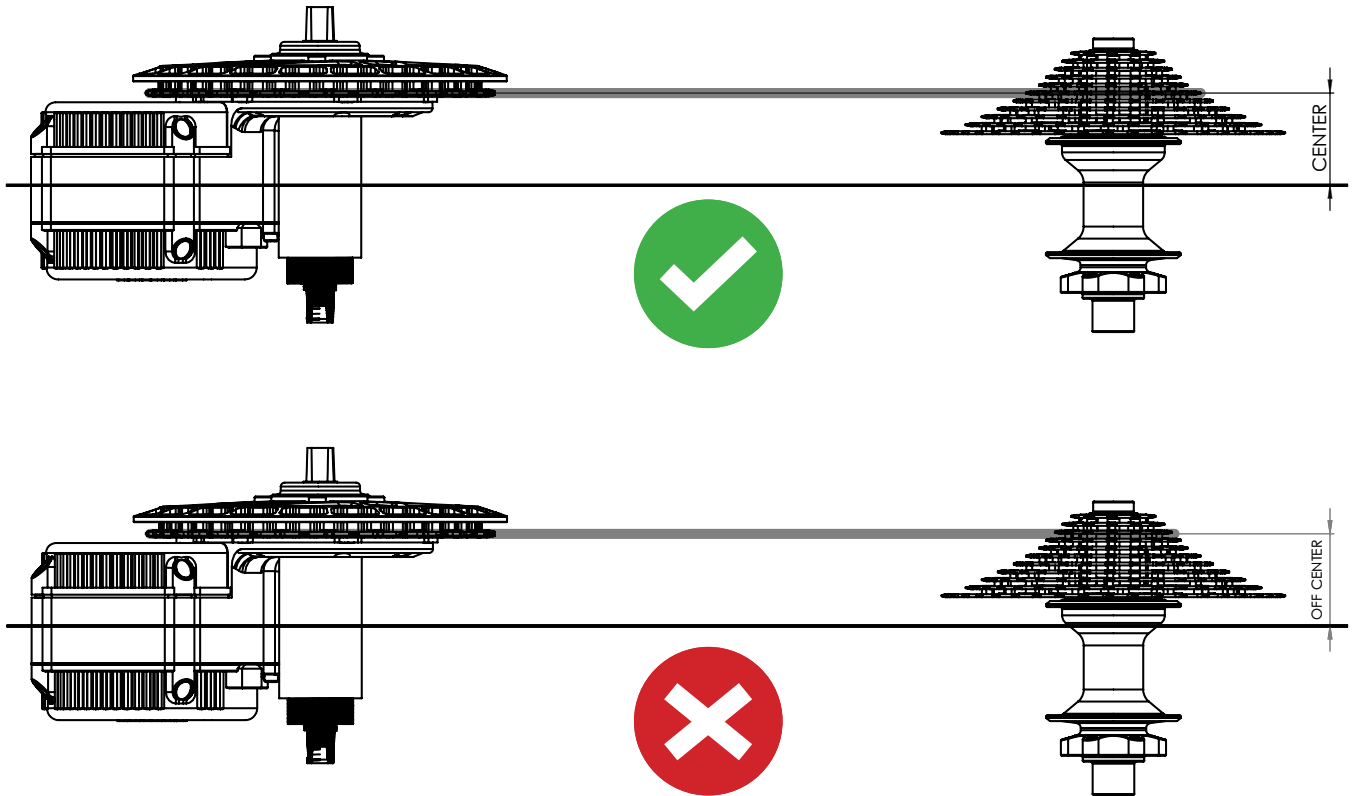

CHAIN COMPATIBILITY

The Lekkie Bling Ring is compatible with most chains up to 11-speed (known to work with some 12 speeds too). If your chain is not sitting well on the chainring try using a Shimano chain compatible with the number of gears. EG HG-X11 11 Speed. Note if the chain is tight on the teeth do not use.

GEOMETRY

Generally the 9mm offset found on the 42T and 46T Blingrings will give you the best possible chainline without interfering with the motor. However chainstay interference is often the limiting factor, the larger the sprocket the closer the chainstay gets, so you may need to use a spacer to clear the chainstay. The smaller diameter of the 40T Blingring should allow you to run greater offset than the 42T or 46T in this case.

WARRANTY

At Lekkie we don't accept anything but the best workmanship and quality. If a part has slipped through our QC system and made it to your hands let us know and we will put it right.

If one of our products fails we want to know so we can make our products better. If you destroy a lekkie product in extreme use tell us. We can learn from this and sell you something so suit your needs.

If you are in anyway unhappy with your Lekkie product get in touch so we can put it right.